

UNIT 1
REGENTS COURT,
WALWORTH IND EST,
ANDOVER, HANTS
SP10 3SQ

TELEPHONE
01264 356415

FACSIMILE
01264 337854



Air Vent Technology Ltd

INSTALLATION AND GENERAL NOTES FOR BELT DRIVEN SUPPLY AND EXTRACT UNITS

PLEASE ENSURE THIS DOCUMENT IS PASSED
ON TO THE END USER OF THIS PRODUCT

GENERAL CONSTRUCTION

Designed for internal applications, the **STP** range of belt driven air movers has a standard construction of a 30mm square extruded aluminium frame fitted with 25mm thick double skinned panels.

Panels have an inner and outer skin of spangled galvanized sheet steel and are lined with 45kg/m³ density mineral wool slab.

Units are mounted on a 100mm high extruded aluminium channel base.

Designed for external applications, the **STR** range of belt driven air movers has a standard construction of a 30mm square extruded aluminium frame fitted with 25mm thick double skinned panels.

Panels have an inner and outer skin of spangled galvanized sheet steel and are lined with 45kg/m³ density mineral wool slab.

The outer skin has a plastic coated finish. Colour: Grey - BS00A05

Units are mounted on a 100mm high extruded aluminium channel base.

Designed for internal applications, the **SPBD & EPBD** range of belt driven air movers and extract fans has a standard construction of a 25mm thick double skinned case.

The case has inner and outer skins of spangled galvanized sheet steel and is lined with 45kg/m³ density mineral wool slab.

Units are mounted on a 100mm high folded GSS channel base.

INSPECTION UPON RECEIPT OF GOODS

Immediately upon receipt of any goods, a careful inspection should be undertaken to ensure neither damage nor missing parts.

Particular attention should be paid to the fan impeller, motor shaft, anti-vibration mounts, flexible connection, coil connections and casework.

In the event of such damage or loss having occurred, inform AVT (01264 356415) **WITHIN 3 WORKING DAYS** of the delivery date, giving the serial number which can be found on the nameplate. After this period we will be unable to entertain any claim for loss or damage.

INSTALLATION

When installing our equipment, the following must be observed.

Safety:-

It is the responsibility of the installer to ensure that the installation complies with the legal regulations and the current HEALTH AND SAFETY AT WORK ACT.

Ambient Temperature:-

The range of units covered by this manual are designed for use in an environment where the ambient air temperature is unlikely to exceed 40°C.

Where temperatures are likely to exceed those stated, please contact AVT (01264 356415).

Cranage:-

Units being craned into position must be handled with care to avoid damage. This applies particularly to weatherproof units, with overhanging lids and cowls, and also painted units. Where lifting lugs are provided these **MUST** be used. A spreader bar should be employed so as to prevent damage to the top of the unit. Strong points are provided on weather lids for straps.

Mounting:-

ALL centrifugal fan units **MUST** be mounted so that the fan shaft is horizontal. Failure to comply will result in fan failure.

Positioning/Assembly:-

All units should be mounted on a completely flat base. Units supplied in sections should be bolted together using the self adhesive rubber tape and fasteners supplied. Once the unit is located in position the **YELLOW TRANSIT BOLT** securing the fan and motor assembly **MUST** be removed.

Duct Connections:-

Adjoining ductwork should always be independently supported to avoid undue stress on the unit casing. Fans are internally isolated thus removing the need for external flexible connections or anti-vibration mounts.

Access:-

All units are designed with easily removable components for maintenance purposes. Sufficient room should be allowed adjacent to the unit to allow components to be withdrawn.

Electrical Wiring:-

All wiring should be undertaken by a competent electrician and should comply fully with the current I.E.E. Wiring regulations.

Wiring diagrams are provided within the motor terminal box.

The electrical supply must be as that stated on the nameplate.

When the wiring is complete, check for free and correct rotation of the fan impeller.

Heat Recovery:-

Units fitted with Cross Flow Plate Heat Exchangers **MUST** not have the supply and extract fans run independently from each other as this will cause damage to the heat exchanger module. It is also recommended that an interlock be fitted within the controls to turn both fans off in the event of one failing.

VEE BELT DRIVES

All units covered by these operating instructions are fitted with a Vee Belt Drive. Before the unit is run, it is essential that drive is checked to ensure correct alignment. The fan and motor shafts **MUST** be parallel. The motor pulley **MUST** be aligned with the fan pulley using a straight edge. Turn the fan shaft by hand to ensure free rotation. The belts should not be over tensioned as this may cause damage to the bearings and excessive wear on the belts. See the following diagrams for tensioning details. Belts should be retensioned after one months running.

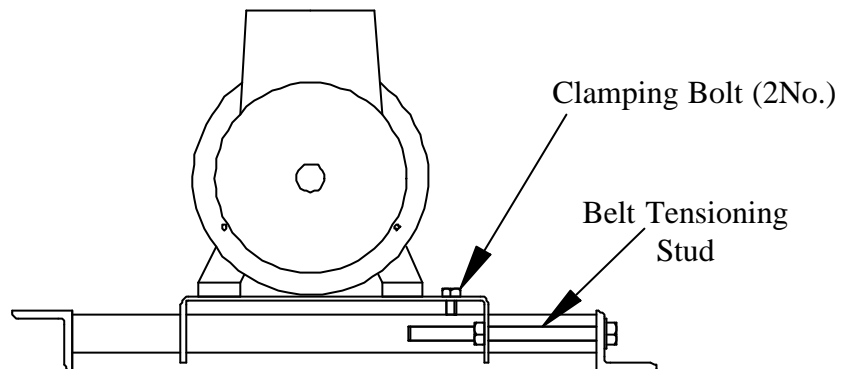

To tighten belt: Slacken off the two clamping bolts, turn the head of the Belt Tensioning Stud until the required tension is achieved. Retighten the two clamping bolts.

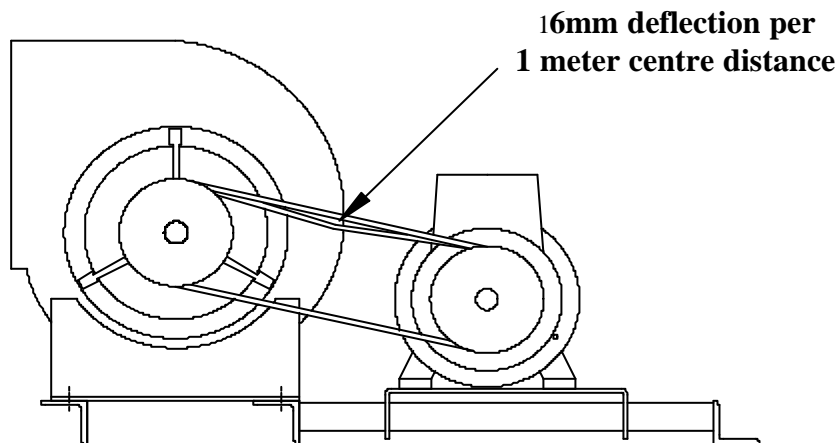

Belts should be inspected on a regular basis, checking for slackness or wear. Any slackness should be taken up as described on the previous page. Wear may be down to miss aligned pulleys - this should be checked.

Under normal conditions, the stretch within new belts will occur in the first few days of operation.

New and used Vee Belts **MUST NOT** be mixed.

Vee Belts of different types or brands **MUST NOT** be mixed.

Always fit new belts of the same set.

HEATING AND COOLING COILS

Winter Conditions:-

It is important that coils are protected against adverse weather during the winter period that may cause freezing and the danger of air being delivered at below 4.5 C. To protect heating coils, a thermostat should be installed down stream of the heater and set to 4.5°C. It's action should be to either stop the fan or close outside air dampers. Chilled water cooling coils fitted upstream of any heating coil should be drained to prevent freezing.

Water Condition:-

It is recommended that a check is made on the water condition to ensure that any treatment to prevent corrosion or scaling has been applied. Information relating to this can be obtained from the relevant Water Authorities particulars which can be found in the Water Engineer Handbook yearly edition.

Run On Facility:-

It must be highlighted that when a heating coil is turned off it does not cool immediately. The residual heat must be dissipated by continuing to run the fan for several minutes after shutdown thus preventing damage to the coil.

Trapping:-

Correct trapping of the condensate line is essential to prevent flooding or liquid splashing back into the drain pan.

Negative pressure drain pan

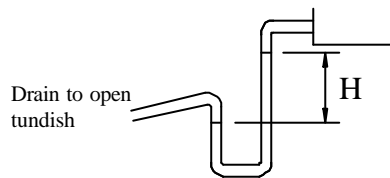

Positive pressure drain pan

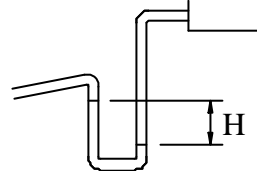

$$\text{Dim H} = \text{TOTAL STATIC PRESSURE mm Wg} + 12\text{mm minimum}$$

WATER COILS

Air Vents and Drain Plugs:-

These are not fitted to the coil but must be fitted in adjacent pipework. The air vent should be fitted at the highest point by the return connection and the drain below the flow connection.

The water flow connection is that on the air off side of the coil.

When the coil is mounted at a high point of the system it **MUST** be regularly vented, otherwise the coil may become air locked with a loss of duty.

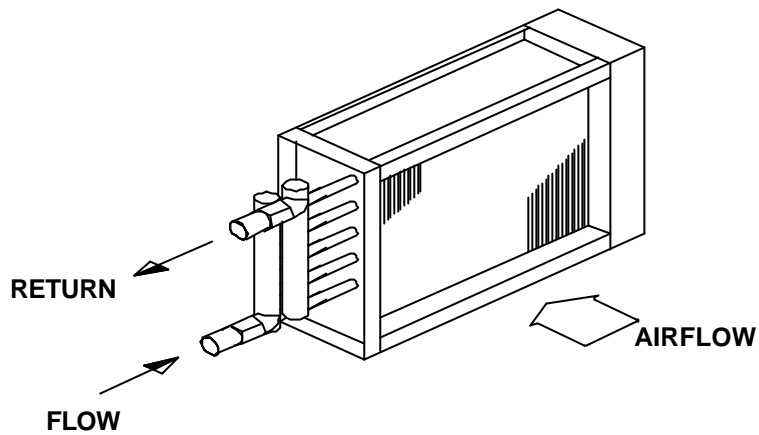

DX COILS

Must be fitted in accordance with accepted codes of practice for refrigeration systems. If fitted upstream of a heating coil, care must be taken to ensure that the air temperature does not fall below 0 C.

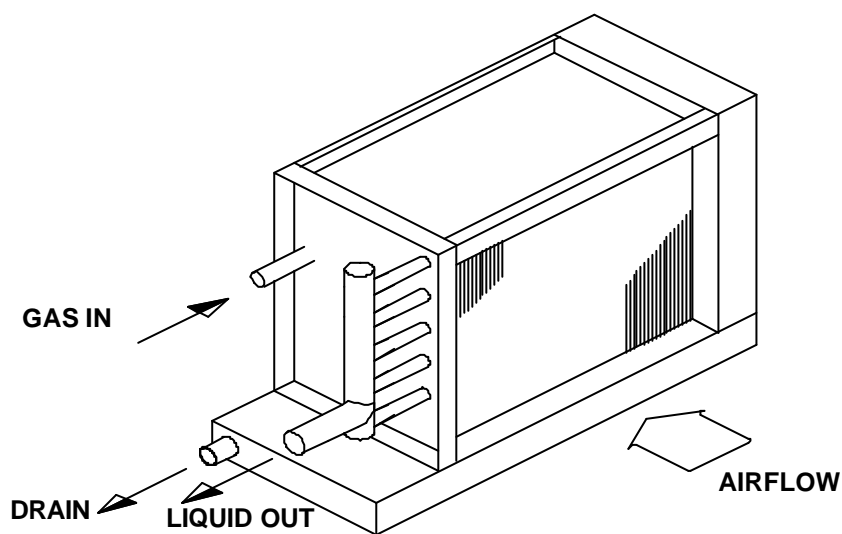

STEAM COILS

Steam coils are suitable for use with saturated steam up to 100psi.

The pipework **MUST** be arranged so as to provide adequate drain lines with a suitable strainer and drain trap.

All steam and drain lines **MUST** be suitably lagged.

The steam supply is to be taken from the top of the steam main to avoid the introduction of moisture or air. The pipe shall be so arranged as to not interfere with the coil expansion.

If the pipe run is excessively long and prone to water logging, it **MUST** be fitted with a suitable trap just before the coil.

If the steam is being fed from a high pressure steam main, a pressure release valve fitted on the low side is required to prevent dangerous overheating of the air

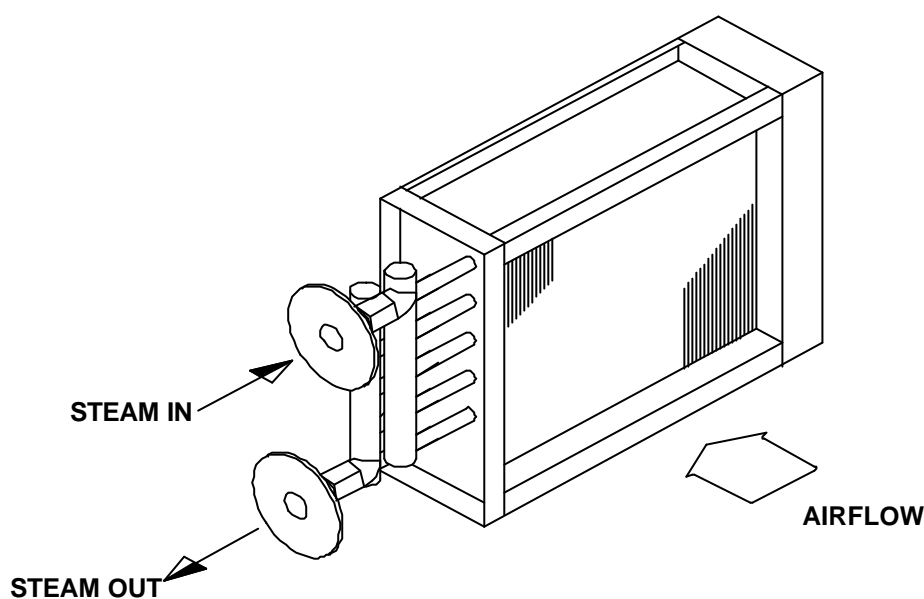

ELECTRIC HEATER BATTERIES

REFER TO SEPARATE MANUAL ENTITLED
**INSTALLATION AND GENERAL NOTES
FOR ELECTRIC HEATER BATTERIES.**

DOCUMENT REF: DO1001

Note: If you are not in possession of the above manual contact AVT (01264 356415) to request a copy. **NO WORK** should be carried out unless you are possession of this document.

MAINTENANCE

3 Monthly:-

Filters should be inspected and if found to be heavily soiled, replaced.
If grease nipples are fitted to any fan/motor bearing or plumber block bearing, then inspect and recharge as necessary.

6 Monthly:-

The fan impeller should be carefully cleaned with a brush. This will prevent the impeller from becoming unduly dirty and become unbalanced.
Coils should be inspected to ensure no foreign material has accumulated on the fins. Should any be found, the fins can be cleaned using a soft brush and a mild detergent solution. Care **MUST** be taken not to damage the fins during this process. Should debris accumulate on the fins on a regular basis, check the filtration system to ensure correct operation.
Damper cogs, blades and frames should be cleaned and lubricated with a PTFE or silicone oil aerosol lubricant.

12 Monthly:-

The security and integrity of all fasteners should be checked. Particular attention should be paid to the impeller fixing onto the fan shaft.
If the unit has a paint finish this should be checked to ensure no deterioration and if necessary repainted with a suitable touchup paint.
Check A.V. mountings and flexible connections for signs of perishing or damage.

NOTE:-

UNDER NO CIRCUMSTANCES SHOULD ANY MAINTENANCE WORK BE ATTEMPTED WITHOUT FIRST ISOLATING COMPLETELY THE UNIT FROM IT'S ELECTRICAL SUPPLY.

SPARES

Spare parts or direct replacements are normally held in stock and are available for a period of up to 10 years from installation.

Any spare part can be ordered by contacting AVT (01264 356415) and quoting the unit serial number which can be found on the nameplate.

A complete list of recommended spares can be issued upon request.