

ANCILLARIES

Speed Controllers

Both electronic QE and auto-transformer controllers QA are available. For quiet applications, the auto-transformer controllers is recommended. Auto-changeover panels are available with options of duty share and Volt free contacts.



Silencers

Cylindrical silencers are available for all sizes in 600mm or 900mm lengths as standard.

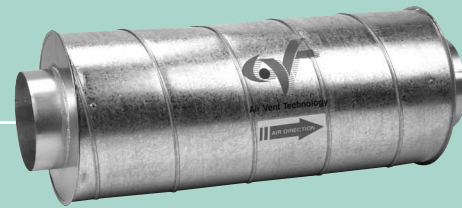

AV Mounts

Rubber type suitable for fixing via mounting feet.



Fast Clamps

Two inch wide frame fitted with a neoprene gasket for airtight connection. Clamps are fitted with quick release fixings.



A STEP FURTHER

As well as the products covered in this leaflet, Air Vent Technology offers an extensive range of supply/extract units and associated ancillary equipment. Catering for air volumes up to 20m³/s and available for internal and external applications, most applications can be accommodated. Among the many variants we are able to cover are the following:

Cases

Single skinned or double skinned with 25mm or 50mm thick panels
 Different panel infill including a combination of high-density rockwool and barrier mat to give high noise reduction.
 Differing panel skin materials including Stainless Steel, Aluminium and plastic coated sheet steel.
 Powder coat paint finish to any BS or RAL number to either internal, external or both surfaces.
 Casings supplied in 'flat pack' form to facilitate site assembly.

Components

The following components can be readily catered for:
 Filters - Carbon, Hepa, Grease, Washable
 Run-a-Round coil systems
 Thermal wheels
 Gas fired heaters - Indirect and Direct
 Fans - SISW, Duplex (for low profile), Twin
 Motors - 1Ph, 2 Speed, Mounted out of airstream, fitted with standby.

Specifications

Units can be designed to meet the requirements of the following specifications:
 DEO Spec 037
 CO4

Controls

Any variation of controls package can be supplied ranging from simple pre-wiring of a motor to an external isolator to an in-built control panel pre-wired to motors, damper motors, sensors, etc..

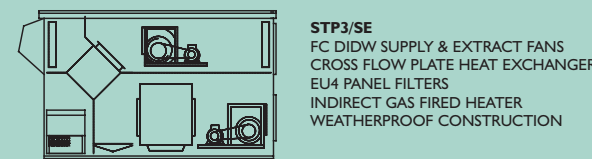
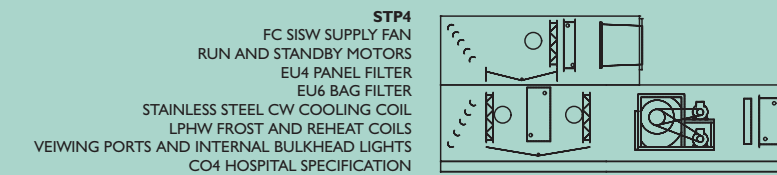
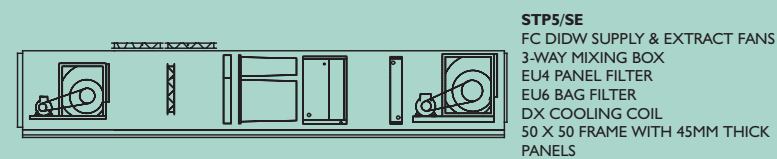

We reserve the right to amend details without notification.



QUALITY RANGE EXTERNALLY MOUNTED TWIN FAN



Plastic coated casing grey - BS00A05

Thermal protection on motor

All models fully speed controllable

Top access for easy maintenance



Unit 1, Regents Court,
 Walworth Industrial Estate,
 Andover, Hampshire SP10 5NX
 Tel: 01264 356415
 Fax: 01264 337854
 email: avt@globalnet.co.uk
 website: <http://www.airventech.co.uk>



Certificate No: GB9455

Leaflet Ref: 506/03/03

UNIT SPECIFICATIONS

Cases

Single skinned construction using sheet steel having a light grey plastic coated exterior.
Colour: BS00A05

Access is via a removable weather lid retained by dome head screws fitted with weather caps.
Lid is cross creased to prevent water pooling.

Discharge is via a weathered outlet cowl fitted with birdmesh.

Fans: Fans are of the double inlet type fitted with forward curved impellers direct driven by induction asynchronous motors with squirrel cage rotor in die cast aluminium. Motors are rated to IP10.

Wiring: Both run and standby fans are pre-wired to an internally mounted terminal box.

Performance

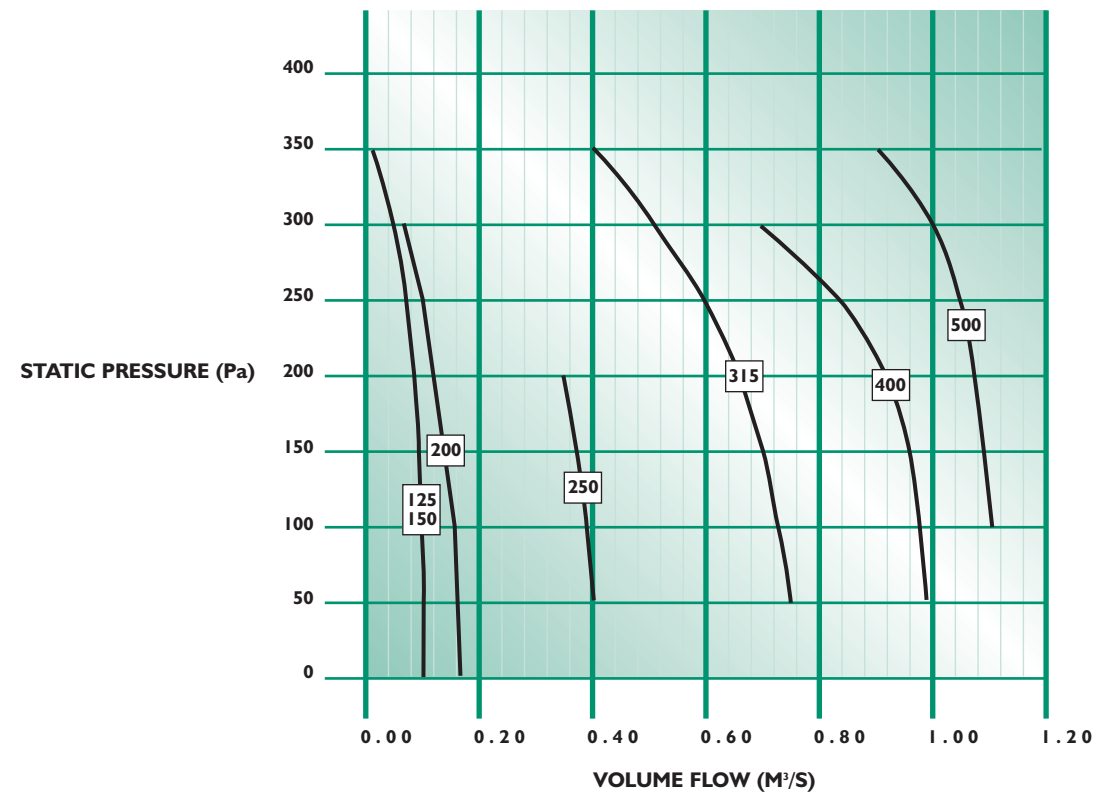

Model	Motor (W)	Supply	FLC (A)	dB(A) @4m (Inlet)	Air flow volume (m³/s) against static pressure (Pa)							
					0	50	100	150	200	250	300	350
EMT125	135	230V I Ph	0.61	36	0.1	0.1	0.096	0.08	0.082	0.067	0.042	0.001
EMT150	135	230V I Ph	0.61	36	0.1	0.1	0.096	0.08	0.082	0.067	0.042	0.001
EMT200	190	230V I Ph	0.85	38	0.18	0.177	0.173	0.166	0.15	0.124	0.0833	
EMT250	147	230V I Ph	1.6	44		0.4	0.387	0.35	0.34			
EMT315	373	230V I Ph	3.85	51		0.75	0.73	0.69	0.65	0.6	0.52	0.4
EMT400	550	230V I Ph	6	55		0.99	0.98	0.95	0.9	0.83	0.68	
EMT500	550	230V I Ph	6.8	56			1.1	1.09	1.07	1.04	1	0.89

Note: Models 250, 315 & 400 not to be selected at less than 50Pa.
Model 500 not to be selected at less than 100 Pa.

DIMENSIONS

Horizontal Intake

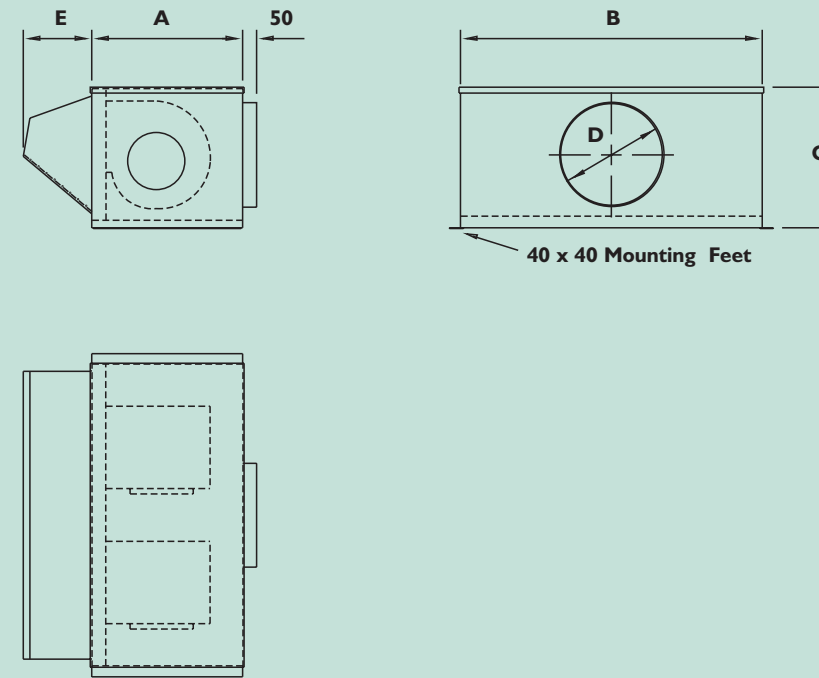

Model	A	B	C	D	E	Weight
EMT125	400	650	375	125	175	19kg
EMT150	400	650	375	150	175	19kg
EMT200	450	800	375	200	175	21kg
EMT250	500	950	450	250	200	45kg
EMT315	650	1000	580	315	250	51kg
EMT400	650	1150	580	400	250	56kg
EMT500	700	1250	580	500	300	84kg

A full range of ancillary items is available to suit the EMT fan range. Speed controllers, silencers, anti-vibration mounts and fast clamps are all available from stock.

DIMENSIONS

Bottom Intake

